

WHEN DISASSEMBLING ALUMINUM EXTRUSION, TIGHTEN ALL SETSCREWS AND LOCKS TO PREVENT LOSS DURING SHIPPING



Using Your Setup Instructions

The Euro LT Hybrids Setup Instructions are created specifically for your configuration. They are laid out sequentially in levels, including exploded views, and a logical series of detailed steps to assemble the main structure and components. We encourage you to study the instructions **before** attempting to assemble your exhibit.

Each page reminds you to tighten the setscrews after disassembling your exhibit to prevent loss of the locks and setscrews (see below in RED). This is VERY IMPORTANT.

Cleaning and Packing Your Display

- 1) Use care when cleaning aluminum extrusion or acrylic inserts. Use only non-abrasive cleaners.
- 2) When cleaning laminate inserts, countertops, or panels use mild cleansers and a soft material such as cotton.
- 3) Keep all display components away from extreme heat and long exposure to sunlight to avoid warping and fading.
- 4) Retain all packing material. It will make re-packing much easier and will reduce the likelihood of shipping damage.

General Setup Instructions for Extrusion System



Most exhibits can be assembled with the supplied Hex Key Tool. Occasionally, a flat head screwdriver may be required.



Most horizontal extrusion connections have a patented expandable lock. This lock inserts into the groove of an opposing extrusion. Tightening the lock with the Hex Key Tool expands the lock and creates a strong positive connection.

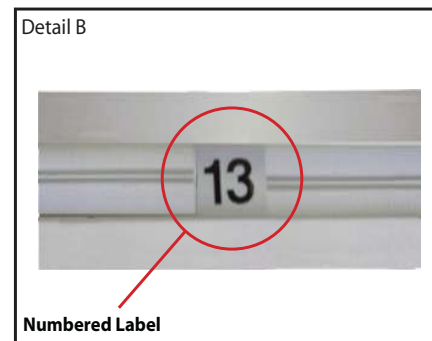

Each extrusion contains a numbered label which corresponds with setup instructions. The label is located within a groove of the extrusion (when possible). With extrusion components the labels contain Black numbers unless otherwise specified.



Remove only (1) setscrew when disassembling. Replace setscrew in extrusion after assembling it. Before packing, replace setscrew in extrusion to avoid losing it.

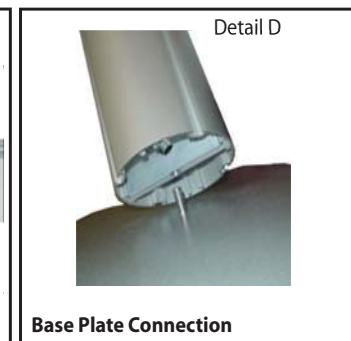

Attach base plate to round or square vertical extrusion using the bolt provided. Be careful not to strip the threads.

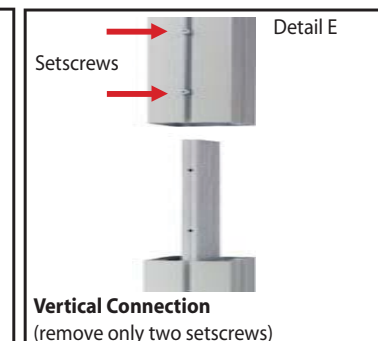

When vertical extrusions are packed in portable cases rather than crates or tubs, they must be broken down into smaller section which then require assembly.

Remove only (2) setscrews when disassembling. Replace setscrews in extrusion after assembling it. Before packing, replace setscrews in extrusion to avoid losing them.

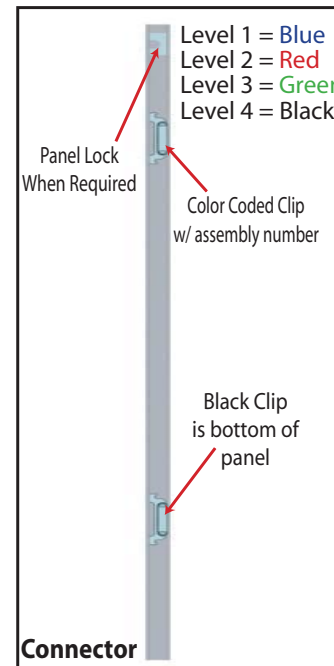

Each component has 2 clips, the lower clip is ALWAYS black. The top clip is color coded to distinguish which level. The color coded clip also contains the numbered label.

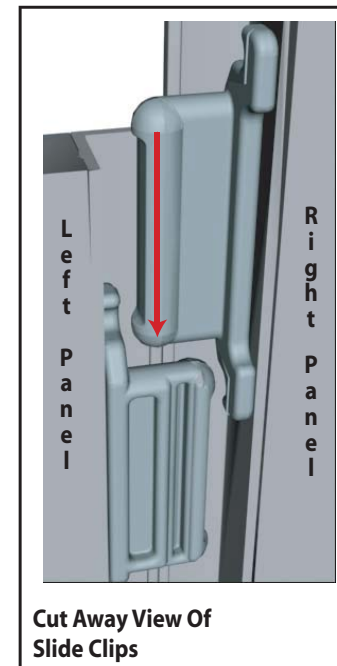

Components connect together by aligning them and sliding downward connecting clips together.

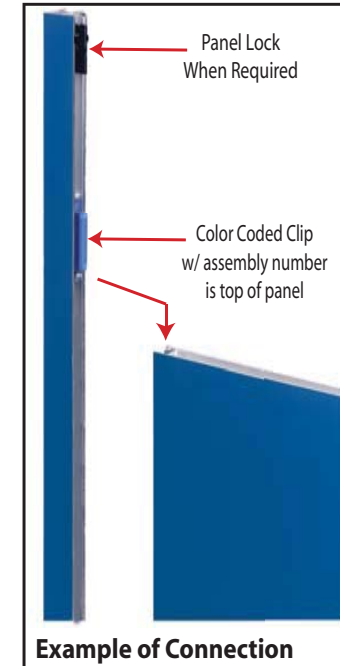

Configurations are assembled from left to right, usually starting with #1 and following the numbered sequence.

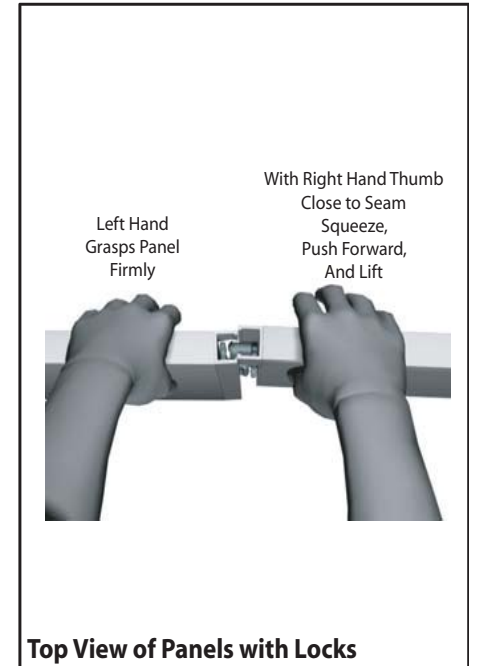

The first level of components contain panel locks that are located at the top of the panel for extra stability and seamless connection. When disassembling panels twist top connection slightly and lift right panel upward.

WHEN DISASSEMBLING ALUMINUM EXTRUSION, TIGHTEN ALL SETSCREWS AND LOCKS TO PREVENT LOSS DURING SHIPPING

Item	Qty. per Step	Description
1	1	Round Base Plate
1a	1	Base Plate w/ 2 Holes
2a/2b	1/1	48" h Vertical Extrusion
3a/3b	2/2	48" h 90° Corner Extrusion
4a	1	47.75" h Round Vertical Extrusion
4b	1	48" h Round Vertical Extrusion
5a	1	47.75" h Round Vertical Extrusion
5b	1	48" h Round Vertical Extrusion
6	1	Vertical Support Extrusion
7	1	Counter Support
8	1	47.20" w Curved Extrusion
9	1	47.20" w Curved Extrusion
10	1	40" w Horizontal Extrusion
11	1	40" w Horizontal Extrusion
12	6	17.87" w Curved Extrusion

Steps:

- 1) Connect extrusions [2a to 2b, 3a to 3b, 4a to 4b and 5a to 5b] together.
- 2) Attach vertical vertical extrusion [5a/5b] to base plates [1] as shown, see detail D on general info page.
- 3) Attach vertical extrusion [4a/4b] and vertical support extrusion [6] to base plate [1a] as shown.
- 4) Attach curved horizontal extrusions [8 and 9] between vertical extrusions [2a/2b and 3a/3b]
- 5) Attach curved horizontal extrusions [12] between vertical extrusions [3a/3b and 4a/4b], placing inserts [A].
- 6) Attach horizontal extrusions [7] between vertical extrusions [4a and 6].
- 7) Attach counter top atop counter support and secure with thumbscrews to vertical extrusion [4a].
- 8) Attach horizontal extrusions [10 and 11] between vertical extrusions [3a/3b and 5a/5b].
- 9) Apply graphics to assembled backwall

Thumbscrew Attachment

After setting counter on horizontal support, put washer on thumbscrew, and attach thumbscrew through counter to vertical extrusion as shown.

Counter Attachment

Note: attach grommet cover after attaching thumbscrews

Note: Attaching Graphics
Attach Backwall Graphics to Velcro by wrapping the Graphic over the Top of the Upper Horizontals and under the Bottom of the Lower Horizontals

Note: Attaching Graphics
Attach Backwall Graphics to Velcro by wrapping the Graphic over the Top of the Upper Horizontals and under the Bottom of the Lower Horizontals

* = Thumbscrew Location
A = Perforated Metal Insert

WHEN DISASSEMBLING ALUMINUM EXTRUSION, TIGHTEN ALL SETSCREWS AND LOCKS TO PREVENT LOSS DURING SHIPPING

Item	Qty. per Step	Description
1a	1	Round Base Plate
14a/14b	2/2	Base Plate w/ 2 Holes
15a	1	48" h 90° Corner Extrusion
15b	1	47.75" h Round Vertical Extrusion
16a/16b	1/1	48" h Round Vertical Extrusion
17	1	48" h Round Vertical Extrusion
18	1	Vertical Support Extrusion
19	1	Counter Support
20	1	40" w Horizontal Extrusion
21	1	40" w Horizontal Extrusion
22	1	47.20" w Curved Extrusion
23	6	47.20" w Curved Extrusion 17.87" w Curved Extrusion

Steps:

- 1) Connect extrusions [14a to 14b, 15a to 15b and 16a to 16b] together.
- 2) Attach vertical extrusion [15a/15b] and vertical support extrusion [17] to base plate [1a] as shown.
- 3) Attach curved horizontal extrusions [21 and 22] between vertical extrusions [14a/14b and 16a/16b].
- 4) Attach curved horizontal extrusions [23] between vertical extrusions [14a/14b and 15a/15b], placing inserts [A].
- 5) Attach horizontal extrusions [19 and 20] between extrusions [5a/5b and 14a/14b].
- 6) Attach horizontal extrusions [18] between vertical extrusions [15a and 17].
- 7) Attach counter top atop counter support and secure with thumbscrews to vertical extrusion [15a].
- 8) Apply graphics to assembled backwall

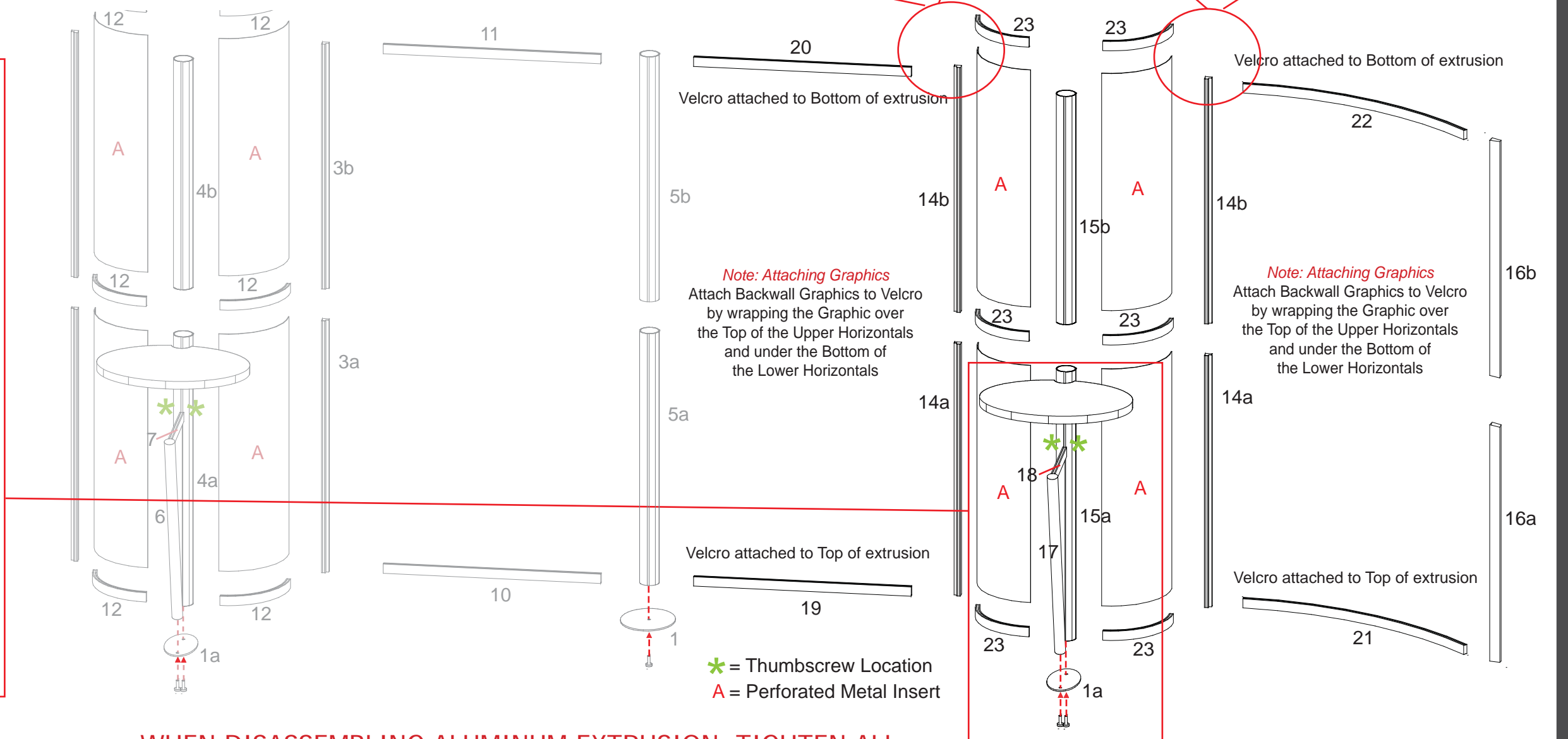
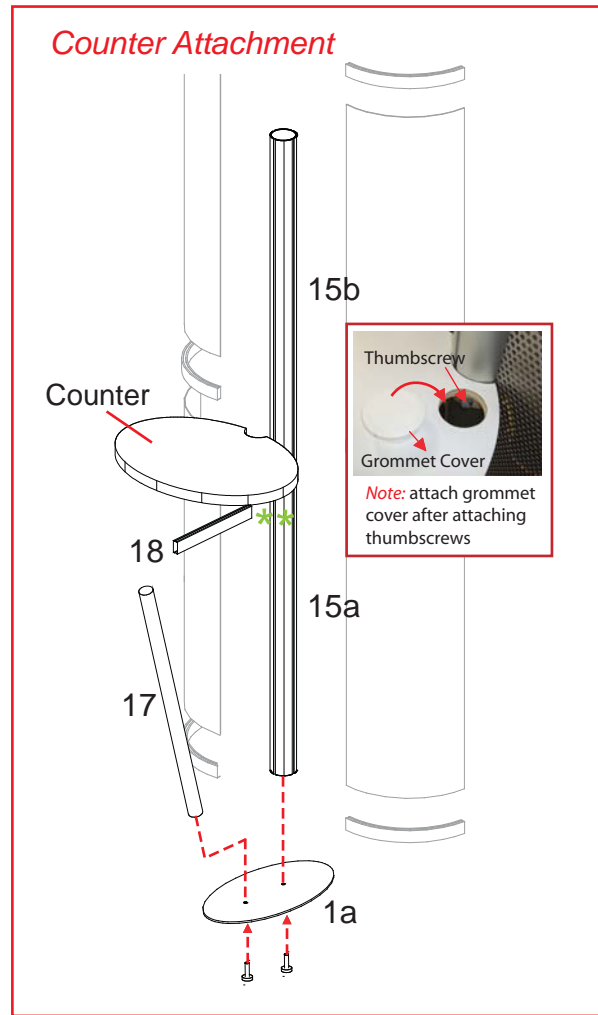

WHEN DISASSEMBLING ALUMINUM EXTRUSION, TIGHTEN ALL SETSCREWS AND LOCKS TO PREVENT LOSS DURING SHIPPING

866.652.2100

Item	Qty.	Description
24	1	57.2" w Curved Horizontal Extrusion
25	1	57.2" w Curved Horizontal Extrusion
26	2	11.42" h Vertical Extrusion
27	1	57.2" w Curved Horizontal Extrusion
28	1	57.2" w Curved Horizontal Extrusion
29	2	11.42" h Vertical Extrusion

Steps:

- 1) Assemble header by attaching vertical extrusions [26] between curve extrusions [24 and 25] as shown.
- 2) Assemble header by attaching vertical extrusions [29] between curve extrusions [27 and 28] as shown.
- 3) Apply graphic to assembled header, then hook header to top of vertical extrusions as indicated.

Hook assembled frame to top of assembled backwall.

Hook assembled frame to top of assembled backwall.

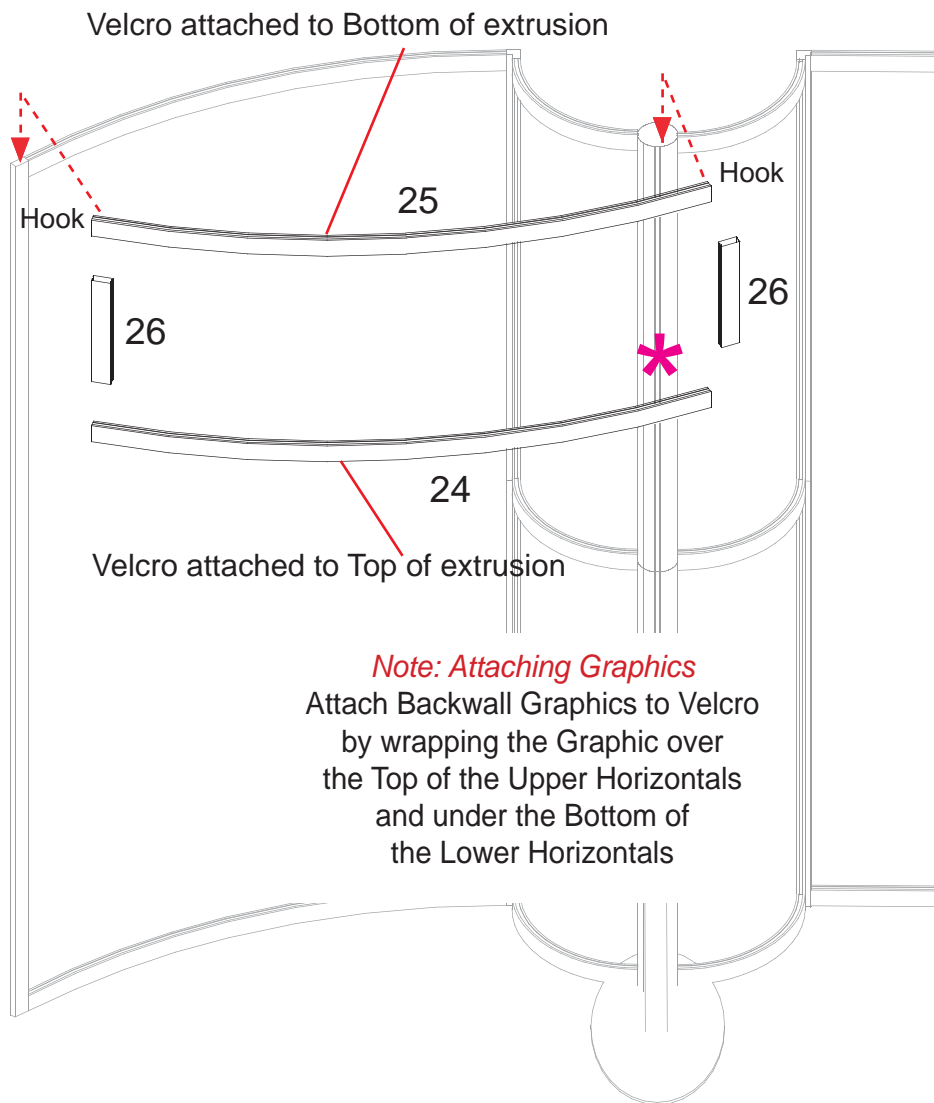

Example of Monitor Mount Attachment

When in desired location tighten in place.

Attach Mount by tightening screws on frontside of Monitor Mount.

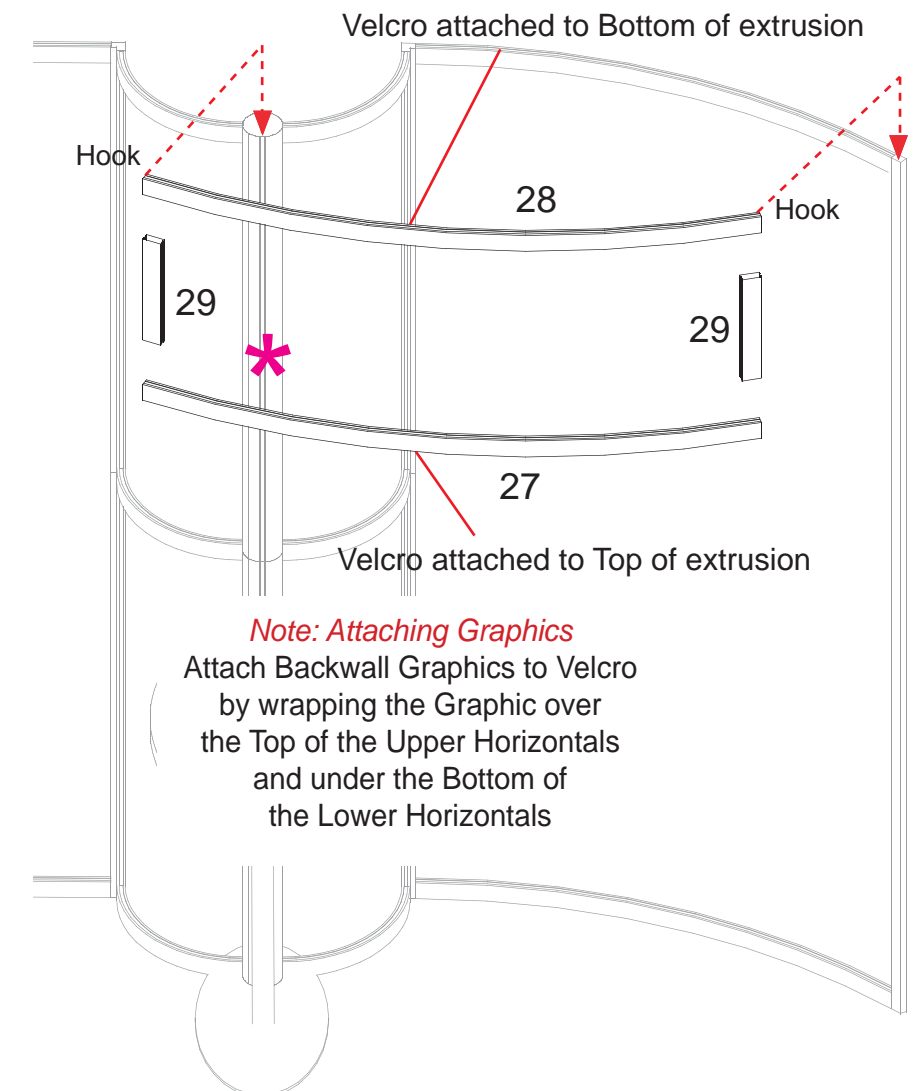

WHEN DISASSEMBLING ALUMINUM EXTRUSION, TIGHTEN ALL SETSCREWS AND LOCKS TO PREVENT LOSS DURING SHIPPING

866.652.2100

Part Number	Qty for Step	Description
1	1	5.75"r X 38"h Quarter Curve Panel
2	1	19"w x 38"h Flat Panel
3	1	5.75"r X 38"h Quarter Curve Panel
4	1	5.75"r X 38"h Quarter Curve Panel
5	1	19"w x 38"h Flat Panel w/Door w/Lock
6	1	5.75"r X 38"h Quarter Curve Panel
30	1	Custom Base Plate
31	1	38"h Curved Round Vertical - Counter Support - Left side
32	1	38"h Curved Round Vertical - Counter Support - Right side
33	2	7" Lower Tapered Horizontal extrusion
34	1	8" Middle Tapered Horizontal extrusion
35	1	16.5" Upper Tapered Horizontal extrusion

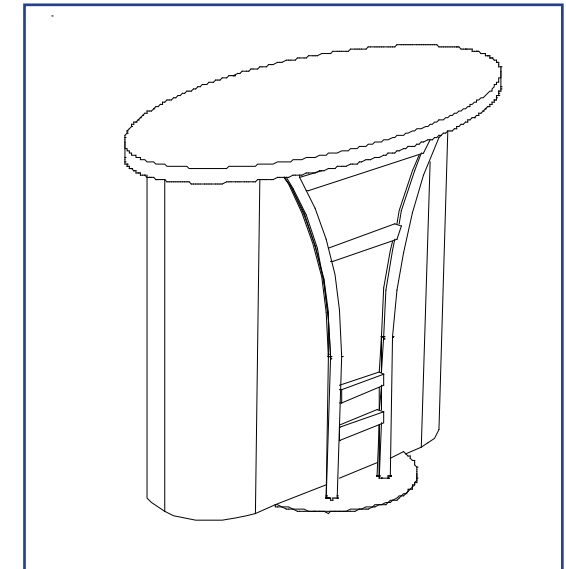

Steps for Back LT Portion of Pedestal:

Use Blue Labels for Step 1.

- 1) Assemble pedestal portion together in numerical order.
- 2) Velcro shelf support to insides of assembled pedestal base.
- 3) Set internal shelf atop shelf supports.

Steps for Front - Aluminum Portion of Pedestal:

Use Black Labels for Steps 4 through 7.

- 4) Attach curved vertical counter supports [31 and 32] to custom base plate [30].
Note: Place Custom Base Plate Centered and Flushed with Back LT Portion of Pedestal.
- 5) Attach both horizontal extrusion [33] between curved round vertical counter supports [31 and 32].
- 6) Attach middle tapered horizontal extrusion [34] between curved round vertical counter supports [31 and 32].
- 7) Attach upper tapered horizontal extrusion [35] between curved round vertical counter supports [31 and 32].
- 8) Attach Counter top with Thumbscrews.

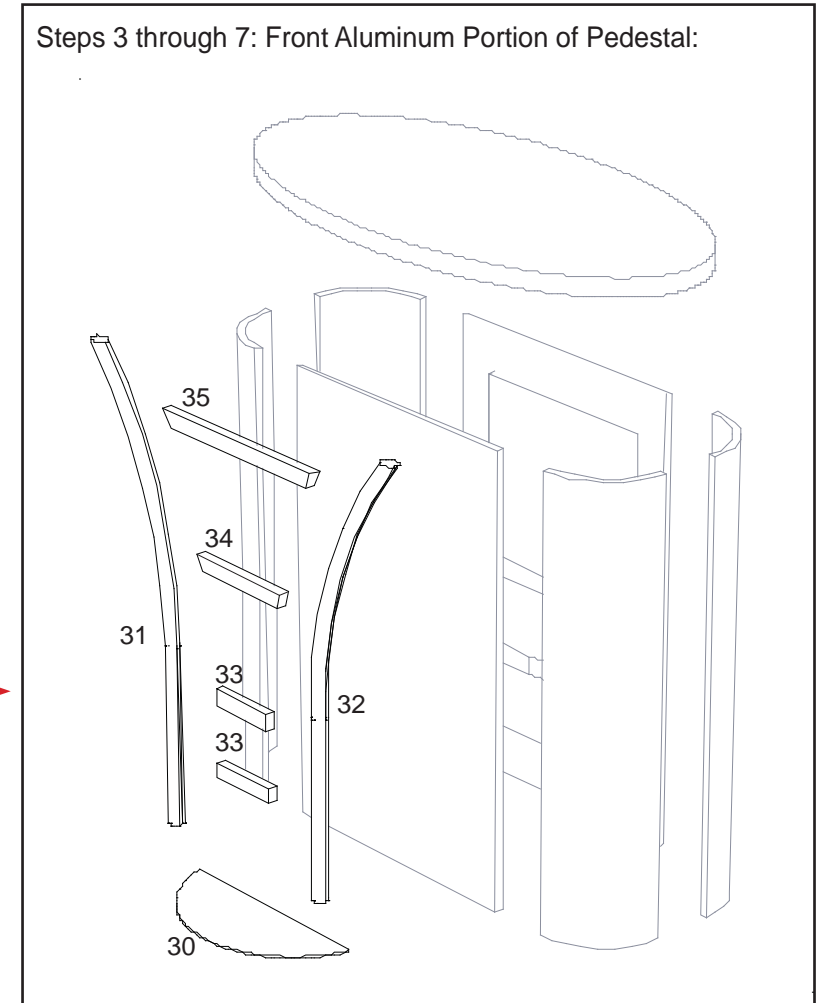
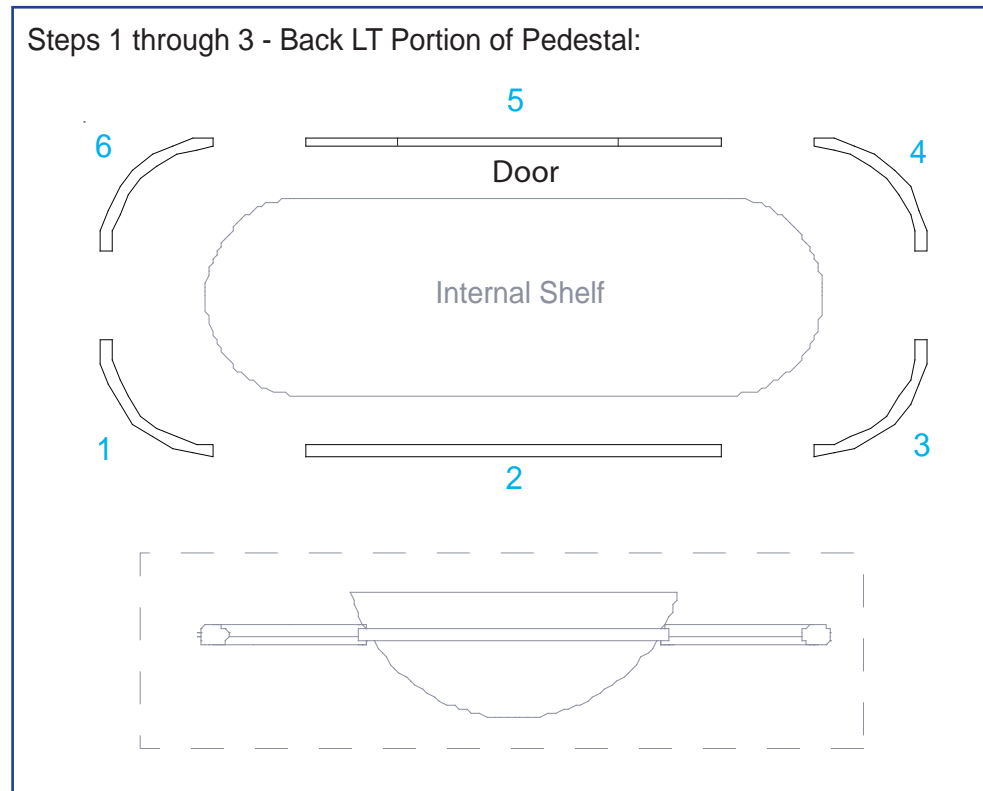

WHEN DISASSEMBLING ALUMINUM EXTRUSION, TIGHTEN ALL SETSCREWS AND LOCKS TO PREVENT LOSS DURING SHIPPING